

VCL 5 - Venti-Cleaner

The VCL 5 system ensures that the knitting machine remains absolutely clean during the production process. The VCL 5 system increases knitting machine efficiency because it prevents the build-up of contamination and deposits which might otherwise stop the machine. The VCL unit consists of a slip ring box, a support arm and electric fans. The slip ring box feeds a continuous power supply to the fans and is available with and without a motor power drive. Various support arm lengths are available. The fan angle can be adjusted for optimum cleaning. Various fan diameters are available. These three factors means that the VCL 5 can customized to fit practically any knitting machine.



Fans: Ø 200, 230 and 280 mm

VCL on a knitting machine

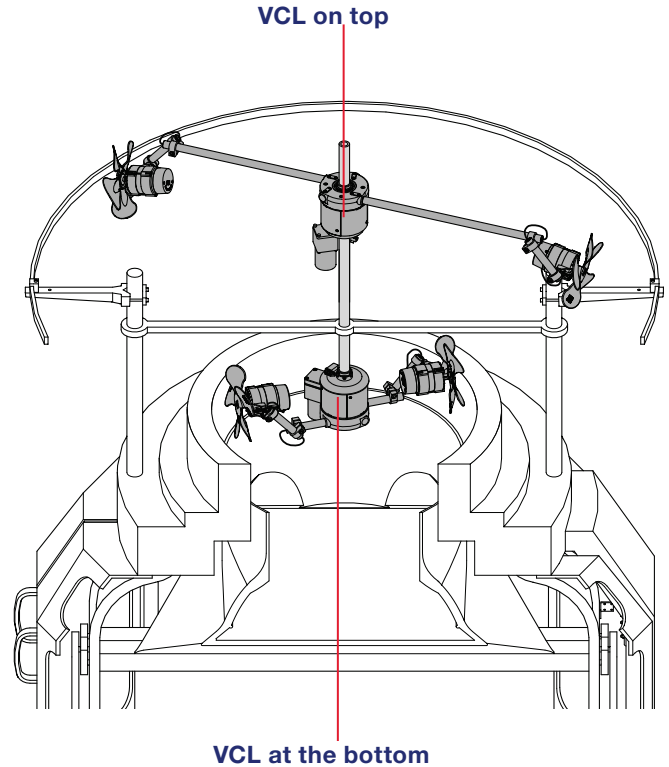

Motor versions



Slip ring box



Motordriven slip ring box
VCL on top



Motordriven slip ring box
VCL at the bottom